

SPINNING REEL 406

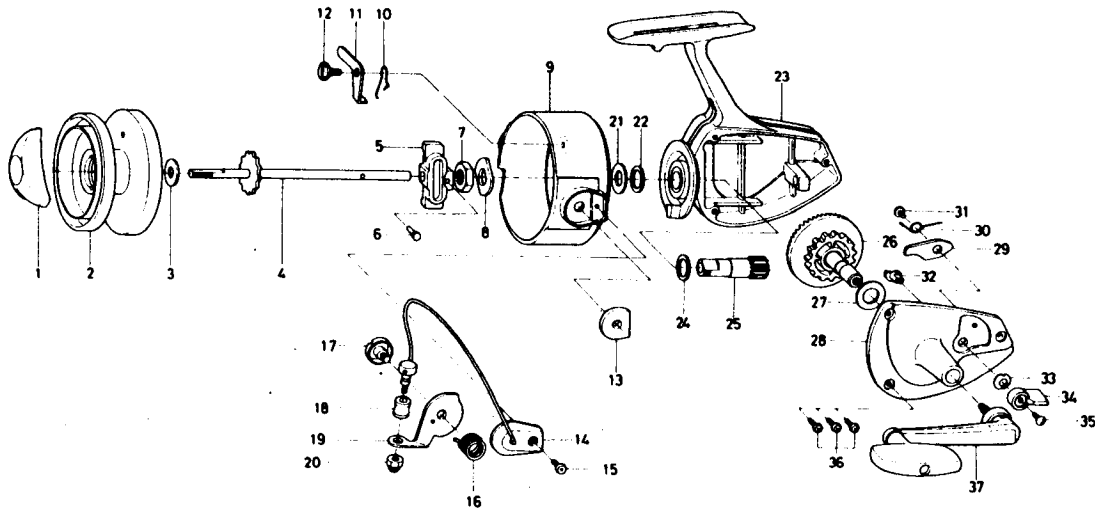

LINE CAPACITY: 250 YDS. 15 LB. TEST (210m Dia. 0.40mm)

Key No.	Parts No.	Parts Name	Key No.	Parts No.	Parts Name
1	60051804	Drag knob	20	63408501	Bail nut
2	K0004351	Spool assembly	21	63707516	Rotor washer A
3	63712731	Spool washer	22	63716420	Rotor washer B
4	67108501	Main shaft	23	67005402	Body
5	64810701	Oscillating slider	24	63716423	Pinion washer
6	61217001	Oscillating slider pin	25	64022601	Pinion
7	63408301	Rótor nut	26	64130801	Drive gear
8	K3724901	Rotor retaining washer	27	63707510	Drive gear washer
9	62017301	Rotor	28	60627401	Body cover
10	61406231	Bail kick lever spring	29	61113501	Anti-reverse claw
11	K5706801	Bail kick lever	30	61440001	Anti-reverse claw spring
12	63631501	Bail kick lever screw	31	63517701	Anti-reverse claw screw
13	62104301	Balancer	32	64612201	Anti-reverse cam
14	K7250221	Bail	33	61501751	Anti-reverse lever washer
15	63516401	Bail holder screw	34	K5403711	Anti-reverse lever
16	61412801	Bail spring	35	63501931	Anti-reverse lever screw
17	63616413	Arm lever screw	36	63518501	Body cover screw
18	K2502801	Line roller	37	67462401	Handle
19	K2308401	Arm lever			