

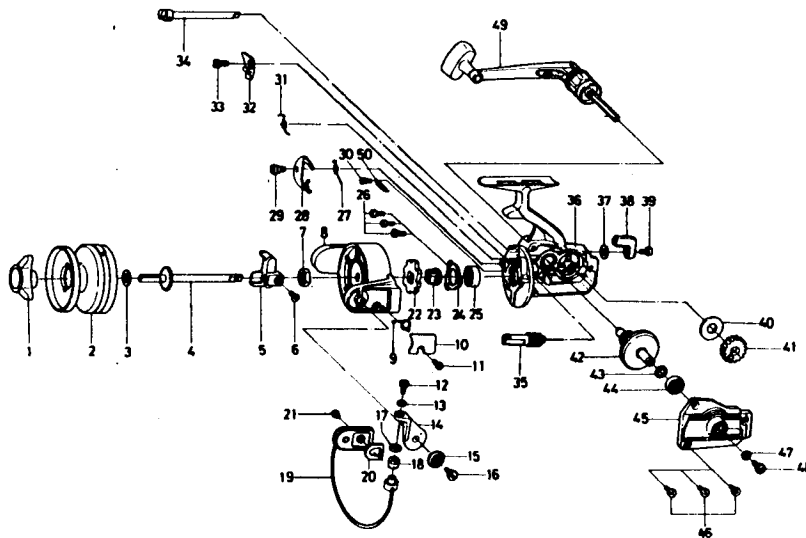

SPINNING REEL

GS-3



LINE CAPACITY: 250 YDS. 15 LB. TEST (225m Dia. 0.40mm)

Key No.	Parts No.	Parts Name	Key No.	Parts No.	Parts Name
1	67402601	Drag knob	26	63516601	Ball bearing ret. washer screw
2	67314702	Spool	27	61440201	Click claw spring
3	63749002	Spool washer	28	67700801	Click claw
4	67109113	Main shaft	29	63633001	Click claw screw
5	64810901	Oscillating slider	30	63633301	Click lever spring screw
6	63518901	Oscillating slider screw	31	61440301	Anti-reverse claw spring
7	63408301	Rotor nut	32	67700711	Anti-reverse claw
8	62017801	Rotor	33	63633601	Anti-reverse claw screw
9	61435311	Bail spring	34	67109001	Anti-reverse cam
10	66326411	Bail spring cover	35	64023201	Pinion gear
11	63522501	Cover screw	36	67006203	Body
12	63633101	Bail screw	37	63732700	Anti-reverse lever washer
13	63751101	Bail washer A	38	65411901	Anti-reverse lever
14	62311901	Arm lever	39	63522501	Anti-reverse lever screw
15	61303201	Bail holder cap	40	63746600	Oscillating gear washer
16	63631901	Arm lever screw	41	64123401	Oscillating gear
17	65012001	Bail washer B	42	64131401	Drive gear
18	62504301	Line roller	43	63712800	Drive gear washer
19	67255601	Bail	44	66317611	Ball bearing
20	62103111	Balancer	45	67058803	Body cover
21	63516601	Bail holder screw	46	63518501	Body cover screw
22	62805301	Ratchet	47	63719521	Handle washer
23	62707001	Click gear	48	63513631	Handle screw
24	66359901	Ball bearing ret. washer	49	67460203	Handle
25	66317611	Ball bearing	50	61441201	Click lever spring