

( SWITCH MOVES UP AND DOWN / REEL IS DARK GREY )

STSP200U

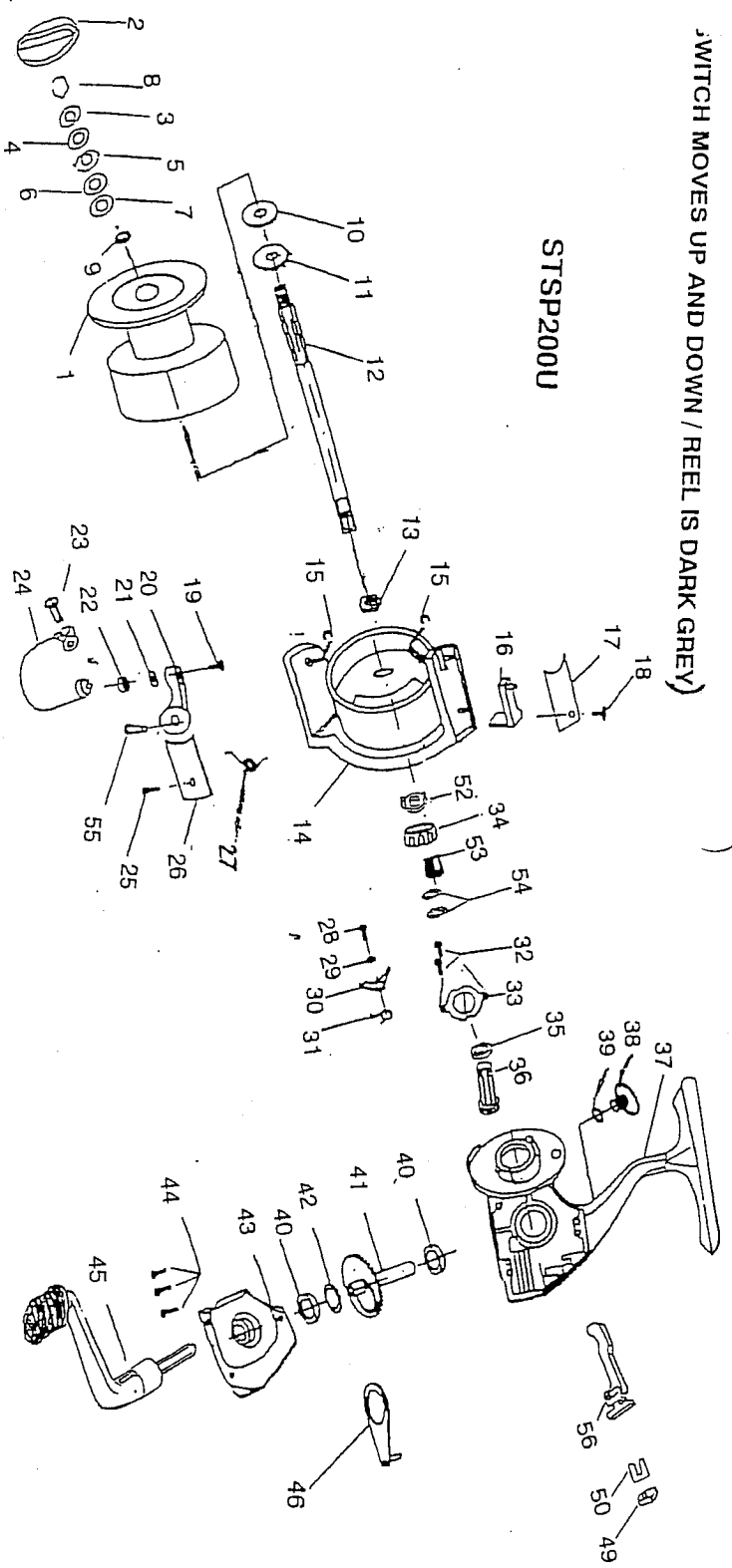

ITEM	DESCRIPTION	PART#	ITEM	DESCRIPTION	PART#	ITEM	DESCRIPTION	PART#
1	SPOOL ASSY ALUM	MIP	20	BALL ARM	MIP	39	HANDLE NUT WASHER	1101890
2	DRAG KNOB	MIP	21	ROLLER WASHER	1101871	40	MAIN BODY BALL BEARING	1101891
3	METAL WASHER	1101725	22	LINE ROLLER	1101872	41	MAIN GEAR	MIP
4	DRAG WASHER	1101726	23	BALL ARM PIN	1101873	42	MAIN GEAR WASHER	1101893
5	EARD WASHER	1101981	24	BALL WIRE ASSY	MIP	43	SIDE COVER	MIP
6	DRAG WASHER	1101727	25	BALL ARM COVER SCREW	1101875	44	SIDE COVER SCREW	1101895
7	METAL SPRING WASHER	1101728	26	BALL ARM COVER	MIP	45	HANDLE ASSY	MIP
8	RETAINER RING	1101724	27	BALL ARM SPRING	MIP	46	OSCILLATION SHAFT	1101897
9	BALL BEARING	MIP	28	A/R PLATE SCREW	MIP	49	A/R SWITCH	MIP
10	MAIN SHAFT WASHER	1101860	29	A/R PLATE WASHER	1101880	50	A/R SPRING	MIP
11	MAIN SHAFT GEAR	1101861	30	A/R PLATE	1101881	52	ROTOR WASHER	1101904
12	MAIN SHAFT	1101862	31	A/R PLATE SPRING	1101882	53	SLEEVE	1101905
13	HEX NUT	1101863	32	BALL BEARING SCREW	1101884	54	WASHER	1101906
14	ROTOR	MIP	33	BB COVER	1101885	55	BALL MOUNT PIN	1101903
15	1/8" CLIP	1101865	34	CLUTCH BB ASSY	1101883	56	A/R SHAFT	MIP
16	BAIL TRIP LEVER	1101866	35	PINION GEAR BALL BEARING	1101886			
17	WEIGHT COVER	MIP	36	PINION GEAR	1101887			
18	WEIGHT COVER SCREW	1101868	37	MAIN BODY	MIP			
19	ROLLER SCREW	1101869	38	HANDLE NUT	MIP			

A/R SWITCH MOVES UP AND DOWN / REEL IS DARK GREY