

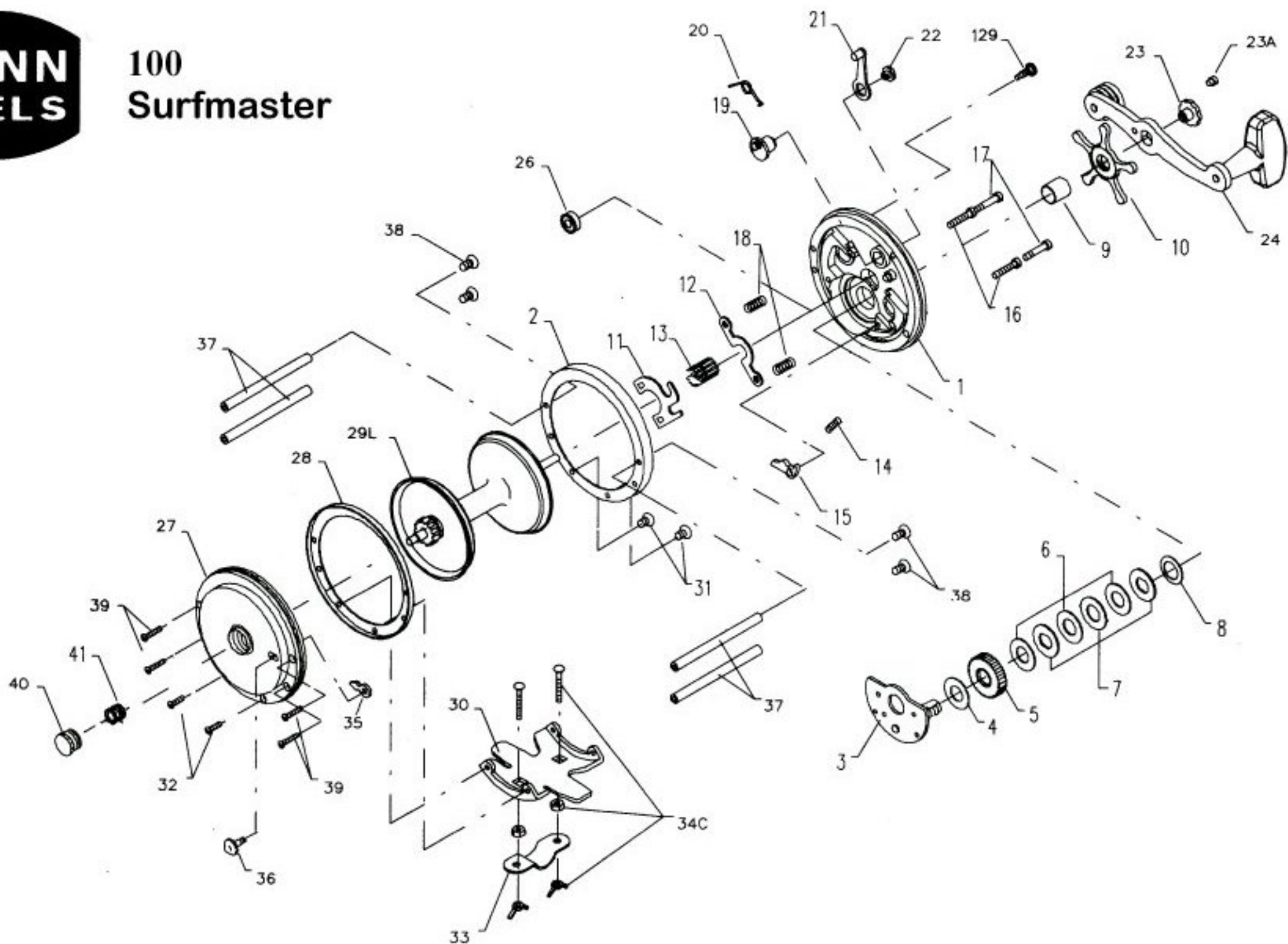

100 Surfmaster



Penn Reel Parts list for:

Model: 100

Surfmaster

KEY PART

NO	NO.	DESCRIPTION
1	1N-100	R.S. PLATE
2	2-200	INNER R.S. RING
3	3-200	BRIDGE W/ SLEEVE
4	4-155	FIBER WASHER
5	5-60	MAIN GEAR
6	6-60	DRAG WASHER
7	7C-60	METAL DISC SET
8	8-60	TENSION SPRING
9	9-60	SPACING SLEEVE
10	10-60	STAR DRAG
11	11-200	ECCENTRIC JACK
12	12-155	PINION YOKE
13	13-200	PINION
14	14-155	DOG SPRING
15	15-200	DOG
16	16-60CH	LOWER BRIDGE SCREW
17	17-70CH	UPPER BRIDGE SCREW
18	18-60	CLUTCH SPRING
19	19-200	ECCENTRIC
20	20-155	ECCENTRIC SPRING
21	21-200	ECCENTRIC LEVER
22	22-99	ECCENTRIC SCREW

KEY PART

NO	NO.	DESCRIPTION
23	23-60	HANDLE SCREW
23A	110-60	HANDLE LOCK SCREW
24	24N-160	COMPLETE HANDLE
26	26-155	R.S. BEARING
27	27-200	L.S. PLATE
28	2-155	INNER L.S. RING
29	29L-100	ALLUMINUM SPOOL
29M	29M-100	METAL SPOOL
30	30-49	STAND
31	31-19	R.S. STAND SCREW
32	32-16CH	L.S. STAND SCREW
33	33-49	ROD CLAMP
34	34C-49	CLAMP SCREW W/NUTS (2 REQ.)
35	35-155	CLICK TONGUE
36	36-60CH	CLICK BUTTON
37	37-180	POST FRAME
38	38-7	R.S. POST SCREW
39	39-5	L.S. POST SCREW
40	40-60	L.S. BEARING
41	41-60	SPRING
129	129-200	TAKE APART THUMB SCREW