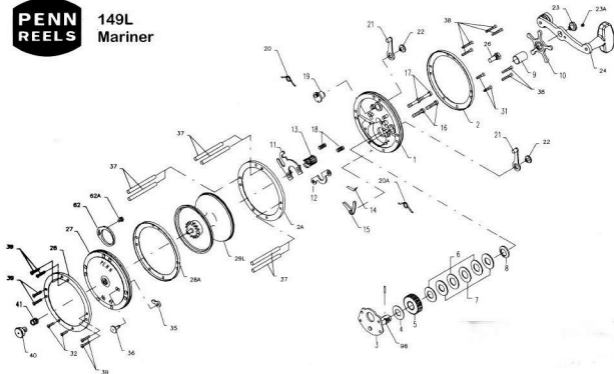

**PENN
REELS****149L
Mariner****Penn Reel Parts list for:****KEY PART**

NO	NO.	DESCRIPTION
1	1-149	R.S. PLATE
2	2-49-OL	OUTER RING
2A	2-49-I	INNER RING
3	3-149	BRIDGE W/ SLEEVE
4	4-60	FIBER WASHER
5	5-149	MAIN GEAR
6	6-60	DRAG WASHER (3 REQ.)
7	7C-60	METAL WASHER SET
8	8-60	TENSION SPRING
9	9-60	SPACING SLEEVE
10	10-49	STAR DRAG WHEEL
11	11-49	ECCENTRIC JACK
12	12-113	PINION YOKE
13	13-113	PINION
14	14-60	DOG SPRING
15	15-149	DOG
16	16-60CH	LOWER BRIDGE SCREW (2 REQ.)
17	17-60CH	UPPER BRIDGE SCREW (2 REQ.)
18	18-60	CLUTCH SPRING (2 REQ.)
19	19-60	ECCENTRIC CAM
20	20-60L	ECCENTRIC SPRING
21	21-49	ECCENTRIC LEVER (1 REQ.)

Model: 149L**KEY PART**

NO	NO.	DESCRIPTION
22	22-60CH	ECCENTRIC SCREW (1 REQ.)
23	23-60	HANDLE SCREW
23A	110-60	HANDLE LOCK SCREW
24	24-49	HANDLE
26	26-60	RIGHT SLEEVE BEARING
27	27-149	LEFT SIDE PLATE
28	28-49-O	OUTER LEFT SIDE RING
28A	2-49-I	INNER RING
29L	29L-49	SPOOL
30	30-180S	STAND
31	38-8	RIGHT/LEFT SIDE STAND SCREW
35	35-60	CLICK TONGUE
36	36-60CH	CLICK BUTTON
37	37-49	POST (6 REQ.)
38	39-6	RIGHT/LEFT SIDE POST SCREW (6 REQ. PER SIDE)
40	40-60	COMPLETE LEFT SIDE BEARING
41	41-60	LEFT SIDE BEARING
62	62-309	CLICK SPRING
62A	63-209	CLICK SPRING SCREW
98	98-60	GEAR SLEEVE
149	149-200	HEX NUT
152	152-200	WING NUT