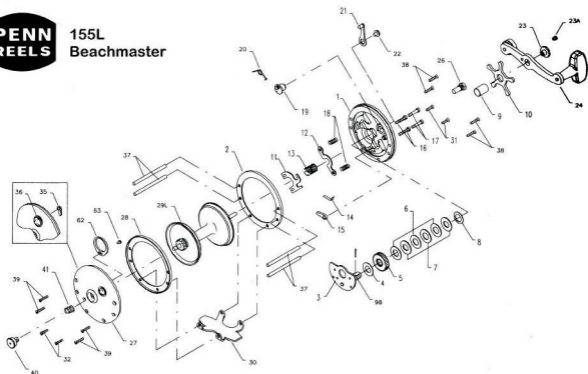

**PENN
REELS****155L
Beachmaster**

Penn Reel Parts list for:

Model: 155L

KEY PART

NO	NO.	DESCRIPTION
1	1-155	RIGHT SIDE PLATE
2	2-155	RIGHT SIDE PLATE
3	3-155	BRIDGE W/ SLEEVE
4	4-155	FIBER WASHER
5	5-155	MAIN GEAR
6	6-155	DRAG WASHER (3 REQ.)
7	7c-155	METAL WASHER SET
8	8-60	TENSION SPRING
9	9-60	SPACING SLEEVE
10	10-60	STAR DRAG WHEEL
11	11-155	ECCENTRIC JACK
12	12-155	PINION YOKE
13	13-155	PINION
14	14-155	DOG SPRING
15	15-155	DOG
16	16-60CH	LOWER BRIDGE SCREW
17	17-60CH	UPPER BRIDGE SCREW
18	18-60	CLUTCH SPRING
19	19-155	ECCENTRIC
20	20-155	ECCENTRIC SPRING
21	21-155	ECCENTRIC LEVER
22	22-60CH	ECCENTRIC SCREW
23	23-60	HANDLE SCREW
23A	110-60	HANDLE LOCK SCREW
24	24-155	HANDLE

KEY PART

NO	NO.	DESCRIPTION
26	26-155	RIGHT SIDE BEARING
27	27-155	LEFT SIDE PLATE
28	2-155	LEFT SIDE RING
29	29L-200	SPOOL
30	30-200	STAND
31	32-22	R.S. STAND SCREW (2 REQ.)
32	32-14CH	L.S. STAND SCREW (2 REQ.)
*	33-200	ROD CLAMP
*	34-200	ROD CLAMP SCREW (2 REQ.)
*	34C-200	ROD CLAMP SCREW W/ NUTS (2 REQ.)
35	35-155	CLICK TONGUE
36	36-155CH	CLICK BUTTON
37	37-155	FRAME POST
38	38-8	RIGHT SIDE PLATE SCREW (4 REQ.)
39	38-8	LEFT SIDE POST SCREW (4 REQ.)
40	40-80	LEFT SIDE BEARING
41	41-80	LEFT SIDE BEARING SPRING
62	62-209	CLICK SPRING
63	63-209	CLICK SPRING SCREW
98	98-155	GEAR SLEEVE
*	149-200	HEX NUT (2 REQ.)
*	152-200	WING NUT (2 REQ.)

* Not Shown