

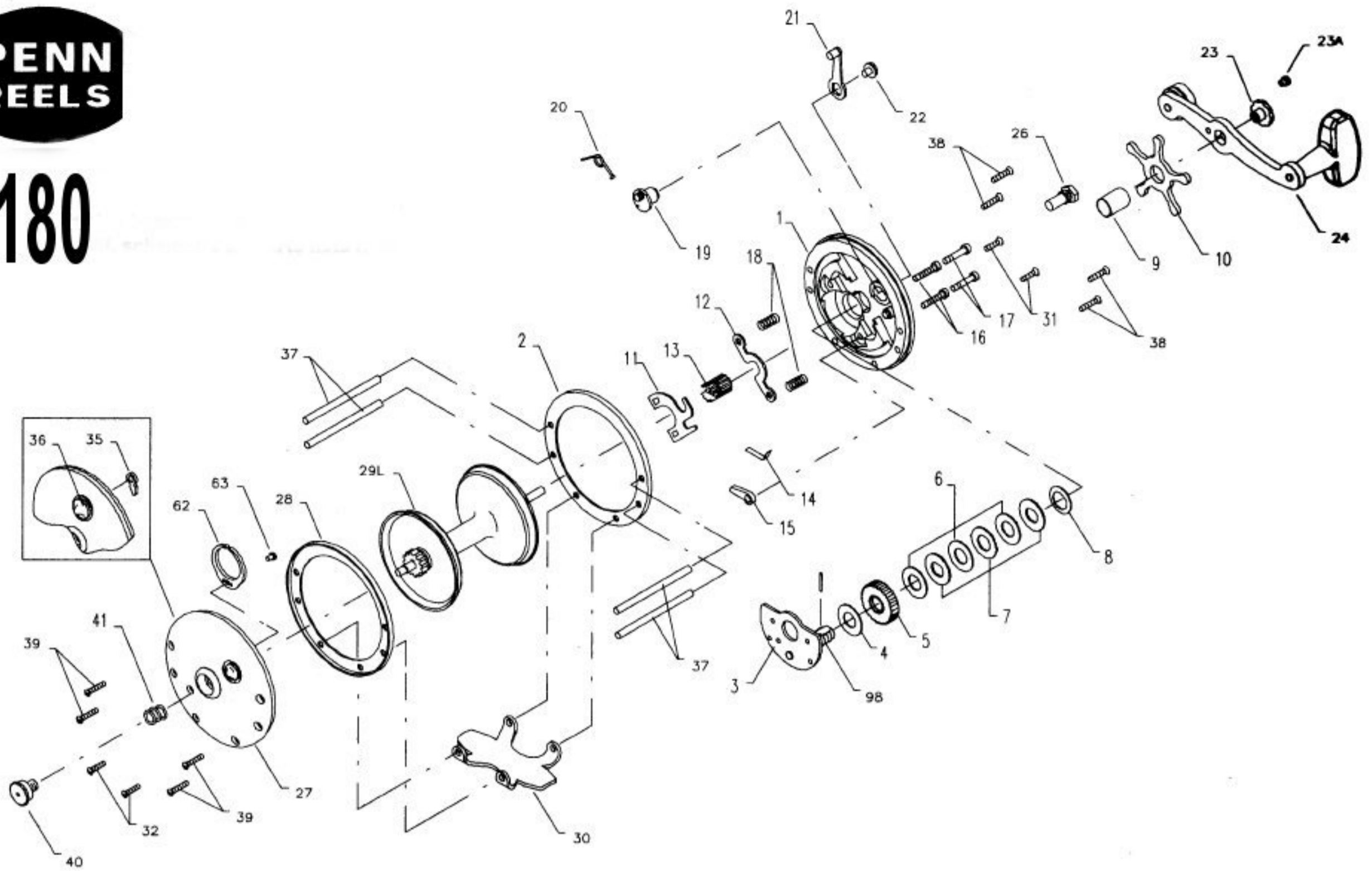

# 180



Penn Reel Parts list for:

Model: 180

**KEY PART**

NO	NO.	DESCRIPTION
1	1-180	RIGHT SIDE PLATE
2	2-155	RIGHT SIDE PLATE
3	3-155	BRIDGE W/ SLEEVE
4	4-155	FIBER WASHER
5	5-155	MAIN GEAR
6	6-155	DRAG WASHER (3 REQ.)
7	7C-155	METAL WASHER SET
8	8-60	TENSION SPRING
9	9-60	SPACING SLEEVE
10	10-180	STAR DRAG WHEEL
11	11-155	ECCENTRIC JACK
12	12-155	PINION YOKE
13	13-155	PINION
14	14-155	DOG SPRING
15	15-155	DOG
16	16-60	LOWER BRIDGE SCREW
17	17-60CH	UPPER BRIDGE SCREW
18	18-60	CLUTCH SPRING
19	19-155	ECCENTRIC

**KEY PART**

NO	NO.	DESCRIPTION
20	20-155	ECCENTRIC SPRING
21	21-155	ECCENTRIC LEVER
22	22-60CH	ECCENTRIC SCREW
23	23-180	HANDLE SCREW
24	24-160	HANDLE
26	26-155	RIGHT SIDE BEARING
27	27-155	LEFT SIDE PLATE
28	2-155	INNER LEFT RING
29	29L-100	SPOOL
30	30-180S	STAND
31	32-22	R.S. STAND SCREW ( 2 REQ.)
32	32-14CH	L.S. STAND SCREW (2 REQ.)
35	35-155	CLICK TOUNGE
36	36-155CH	CLICK BUTTON
37	37-180	FRAME POST
38	38-8	RIGHT SIDE PLATE SCREW (4 REQ.)
39	39-4	LEFT SIDE POST SCREW (4 REQ.)
40	40-60	LEFT SIDE BEARING
41	41-60	LEFT SIDE BEARING SPRING