

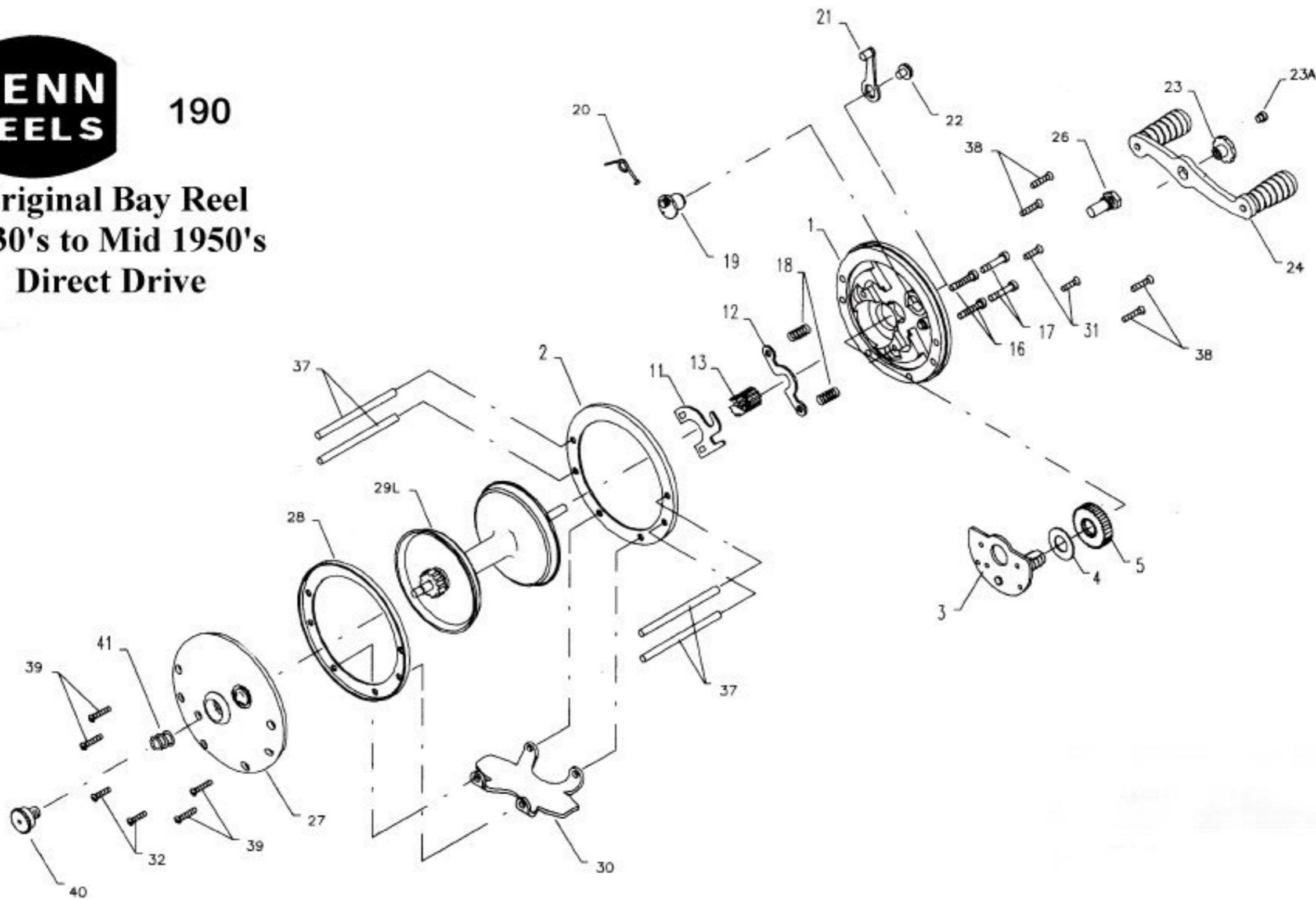

190

**Original Bay Reel  
1930's to Mid 1950's  
Direct Drive**



**Penn Reel Parts list for:**

**Model: 190 Original Bay Reel (1930s to mid-1950s)**

**KEY PART**

**KEY PART**

NO	NO.	DESCRIPTION
1	1-190old	RIGHT SIDE PLATE
3	3-165	BRIDGE W/ SLEEVE
4	4-155	FIBER WASHER
5	5-165	MAIN GEAR
11	11-155	ECCENTRIC JACK
12	12-155	PINION YOKE
13	13-155	PINION
16	16-60CH	LOWER BRIDGE SCREW
17	17-60CH	UPPER BRIDGE SCREW
18	18-60	CLUTCH SPRING
19	19-155	ECCENTRIC
20	20-155	ECCENTRIC SPRING
21	21-155	ECCENTRIC LEVER
22	22-60CH	ECCENTRIC SCREW

NO	NO.	DESCRIPTION
23	23-85	HANDLE SCREW
24	24-109	HANDLE, TWO KNOB
26	26-155	RIGHT SIDE BEARING
27	27-190OLD	LEFT SIDE PLATE
29	29L-100	SPOOL, ALUMINUM (Old 29M Bronzed Metal, 29P Plastic Spools)
30	30-180S	STAND
31	32-16CH	R.S. STAND SCREW ( 2 REQ.) (OLD# 31-285)
32	32-14CH	L.S. STAND SCREW (2 REQ.) (OLD# 32-155)
37	37-180	FRAME POST
38	38-8	RIGHT SIDE PLATE SCREW (4 REQ.) (OLD#31-60)
39	32-22	LEFT SIDE POST SCREW (4 REQ.) (OLD#31-155)
40	40-60	LEFT SIDE BEARING
41	41-60	LEFT SIDE BEARING SPRING