

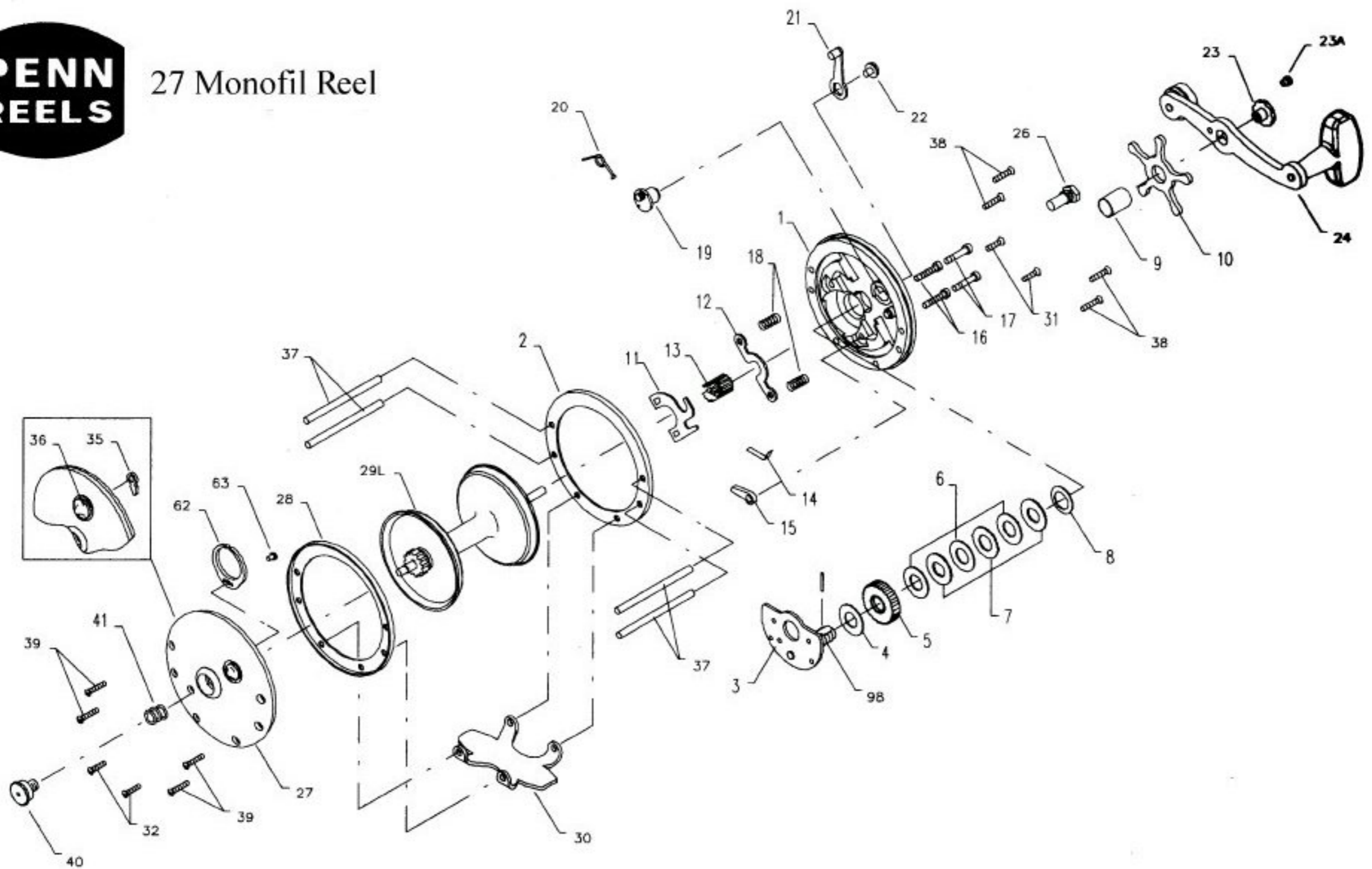

27 Monofil Reel



Penn Reel Parts list for:

Model: 27

Monofil

KEY NO	PART NO.	DESCRIPTION	KEY NO	PART NO.	DESCRIPTION
1	1-27	R.S. PLATE	22	22-60CH	ECCENTRIC SCREW
2	2-155	R.S. RING	23	23-60	HANDLE SCREW
3	3-155	BRIDGE W/ SLEEVE	23A	110-60	HANDLE LOCK SCREW
4	4-155	FIBER WASHER	24	24N-160	HANDLE
5	5-155	MAIN GEAR	25	25-160	KNOB, RIVET & OILER
6	6-155	DRAG WASHER	26	26-155	R.S. BEARING
7	7C-155	METAL WASHER SET	27	27-25	L.S. PLATE
8	8-60	TENSION SPRING	28	2-155	L.S. RING
9	9-60490	SPACING SLEEVE	29	29-27	PLASTIC SPOOL
10	10-60	STAR DRAG WHEEL	29M	29M-27	METAL SPOOL
11	11-155	ECCENTRIC JACK	30	30-180S	STAND
12	12-155	PINION YOKE	31	32-22	R.S. STAND SCREW
13	13-155	PINION	32	32-14CH	L.S. STAND SCREW
14	14-155	DOG SPRING	35	35-155	CLICK TONGUE
15	15-155	DOG	36	36-155CH	CLICK BUTTON
16	16-60CH	LOWER BRIDGE SCREW	37	37-180	FRAME POST
17	17-60CH	UPPER BRIDGE SCREW	38	38-8	R.S. POST SCREW
18	18-60	CLUTCH SPRING	39	32-22	L.S. POST SCREW
19	19-155	ECCENTRIC	40	40-60	L.S. BEARING
20	20-155	ECCENTRIC SPRING	41	41-60	BEARING SPRING
21	21-155	ECCENTRIC LEVER	62	62-209	CLICK SPRING
			63	63-209	CLICK SPRING SCREW
			98	98-155	BRIDGE SLEEVE