

PENN PARTS SCHEMATIC 285

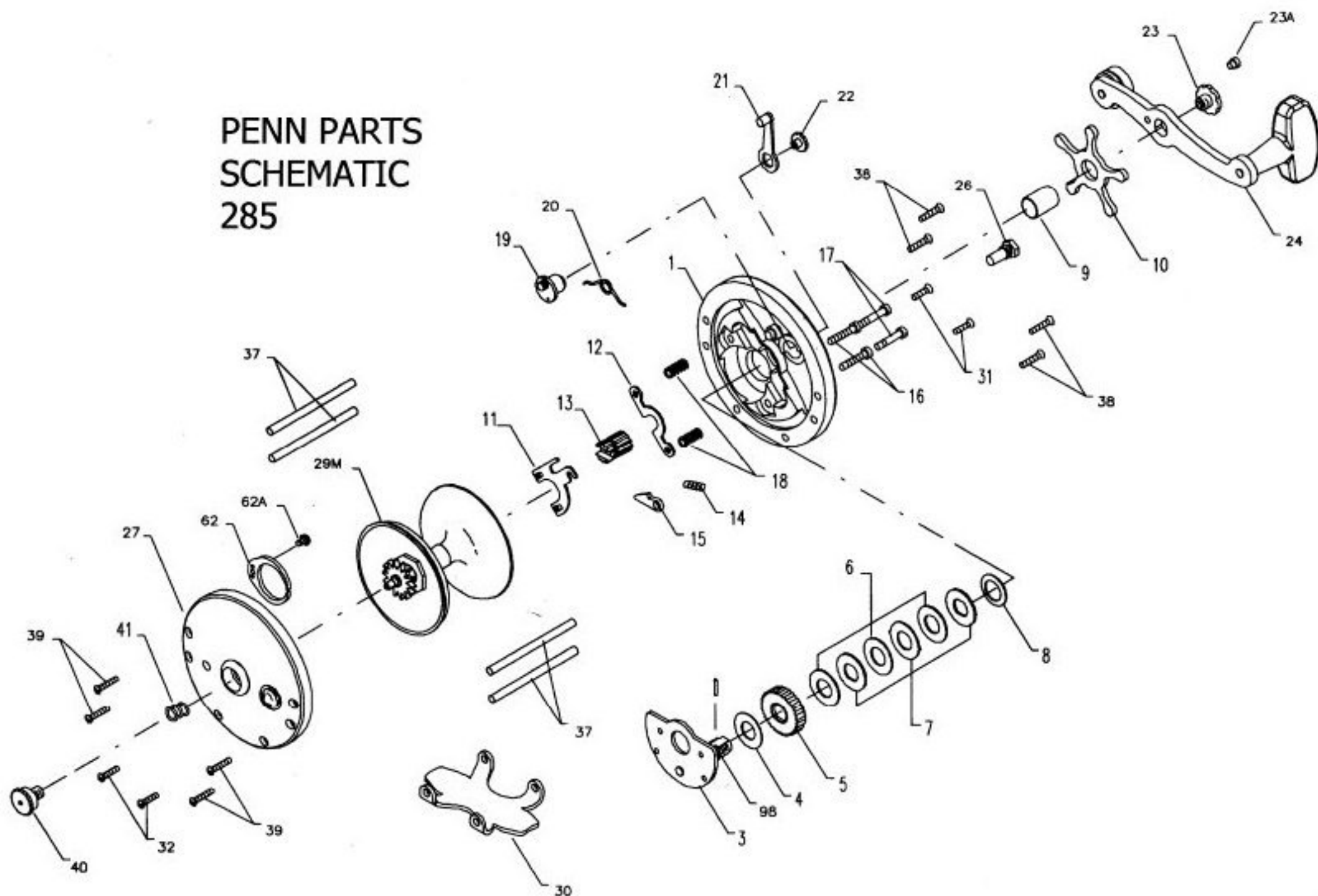

Penn Reel Parts list for:

Model: 285

DELMAR

KEY PART

NO	NO.	DESCRIPTION
1	1-285	RIGHT SIDE PLATE
3	3-66	BRIDGE W/ SLEEVE
4	4-60	FIBER WASHER
5	5-60	MAIN GEAR
6	6-60	DRAG WASHER (3 REQ.)
7	7C-60	METAL WASHER SET
8	8-60	TENSION SPRING
9	9-60	SPACING SLEEVE
10	10-60	STAR DRAG WHEEL
11	11-60	ECCENTRIC JACK
12	12-60	PINION YOKE
13	13-85	PINION
14	14-99	DOG SPRING
15	15-99	DOG
16	16-60CH	LOWER BRIDGE SCREW
17	17-60CH	UPPER BRIDGE SCREW
18	18-60	CLUTCH SPRING
19	19-60	ECCENTRIC
20	20-60L	ECCENTRIC SPRING

KEY PART

NO	NO.	DESCRIPTION
21	21-285	ECCENTRIC LEVER
22	22-60CH	ECCENTRIC SCREW
23	23-60	HANDLE SCREW
23A	110-60	HANDLE LOCK SCREW
24	24-155	HANDLE
26	26-60	R.S. BEARING
27	27-285	LEFT SIDE PLATE
29	29L-85	SPOOL
30	30-60	STAND
31	32-16CH	R.S. STAND SCREW
32	32-22	L.S. STAND SCREW
37	37-60	FRAME POST
38	38-8	R.S. POST SCREW
39	38-8	L.S. POST SCREW
40	40-60	L.S. BEARING
41	41-60	L.S. BEARING SPRING
62	62-309	CLICK SPRING
62A	63-209	CLICK SPRING SCREW
98	98-60	GEAR SLEEVE