

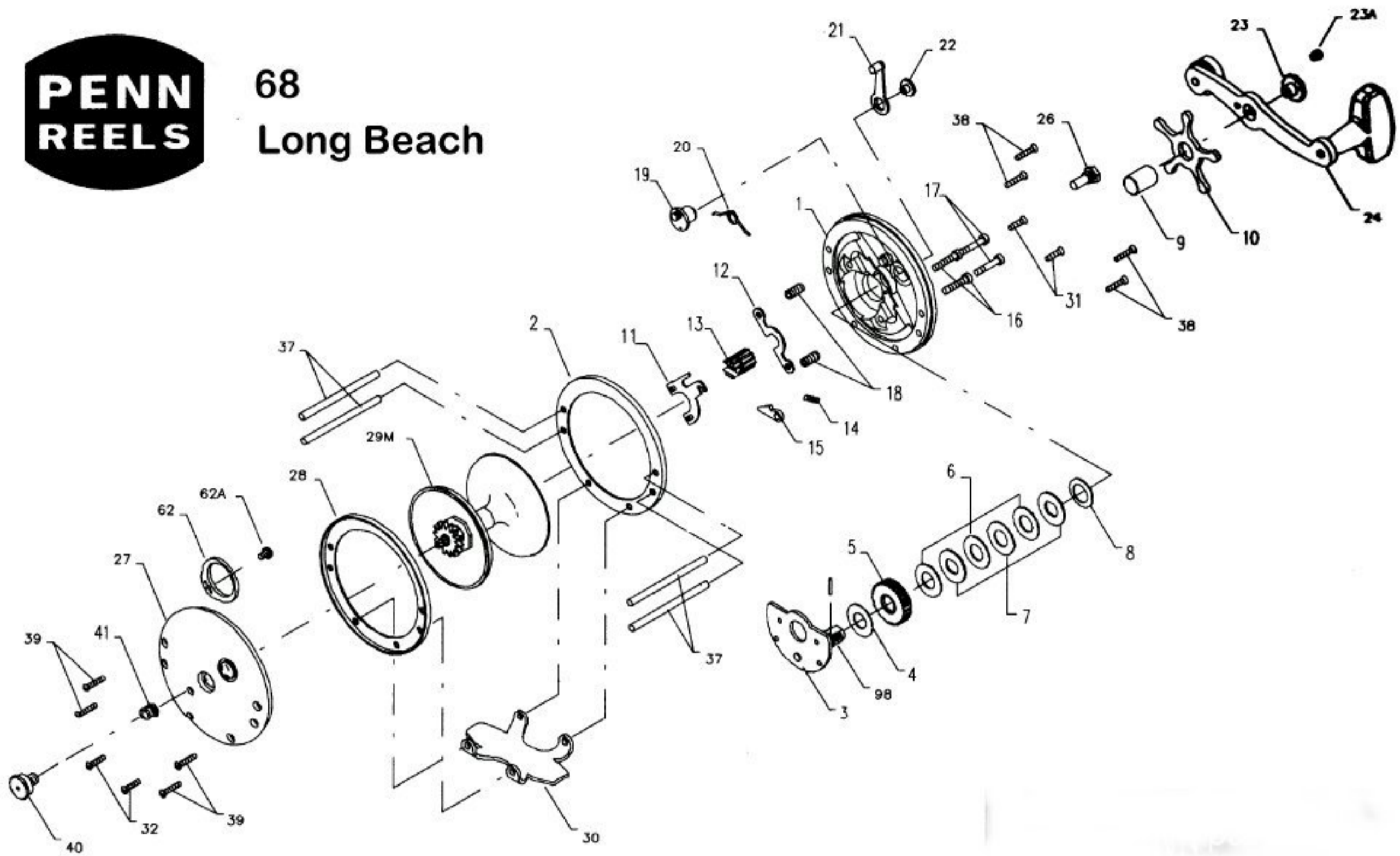

# 68 Long Beach



### Penn Reel Parts list for:

### Model: 68

KEY NO	PART NO.	DESCRIPTION
1	1-68	RIGHT SIDE PLATE
2	2-66	RIGHT SIDE RING
3	3-66	BRIDGE W/ SLEEVE
4	4-60	FIBER WASHER
5	5-66	MAIN GEAR
6	6-113	DRAG WASHER (3 REQ.)
7	7C-60	METAL WASHER
8	8-60	TENSION SPRING
9	9-66	SPACING SLEEVE
10	10-66	STAR DRAG WHEEL
11	11-66	ECCENTRIC JACK
12	12-60	PINION YOKE
13	13-49	PINION
14	14-99	DOG SPRING
15	15-99	DOG
16	16-60CH	LOWER BRIDGE SCREW (2 REQ.)
17	17-60CH	UPPER BRIDGE SCRW (2 REQ.)
18	18-60	CLUTCH SPRING (2 REQ.)
19	19-60	ECCENTRIC
20	20-60L	ECCENTRIC SPRING
21	21-66	ECCENTRIC LEVER
22	22-60CH	ECCENTRIC SCREW
23	23-60	HANDLE SCREW
23A	110-60	HANDLE LOCK SCREW

KEY NO	PART NO.	DESCRIPTION
24	24-86	HANDLE
26	26-60	RIGHT SIDE BEARING
27	27-66	LEFT SIDE PLATE
28	2-66	LEFT SIDE RING
29	29M-68	SPOOL
30	30-68	STAND
31	38-8	RIGHT SIDE STAND SCREW
32	32-16CH	LEFT SIDE STAND SCREW
*	34C-45	ROD CLAMP SCREW W/ NUTS
*	33-113	ROD CLAMP
*	33R-200	RINGED ROD CLAMP (OPTIONAL)
*	34-45	CLAMP SCREW ONLY
37	37-113HLW	FRAME POST
38	39-6	RIGHT SIDE POST SCREW
39	39-5	LEFT SIDE POST SCREW
40	40-60	LEFT SIDE BEARING
41	41-60	LEFT SIDE BEARING SPRING
62	62-309	CLICK SPRING
62A	63-209	CLICK SPRING SCREW
98	98-60	GEAR SLEEVE
*	149-45	CLAMP NUT
*	149-200	HEX NUT

**\* NOT SHOWN**