

**PENN
REELS**

Penn Reel Parts Schematic

113HLW Senator 4/0 - 1989ver. NO Clicker Framework is Posts/SpacerBars

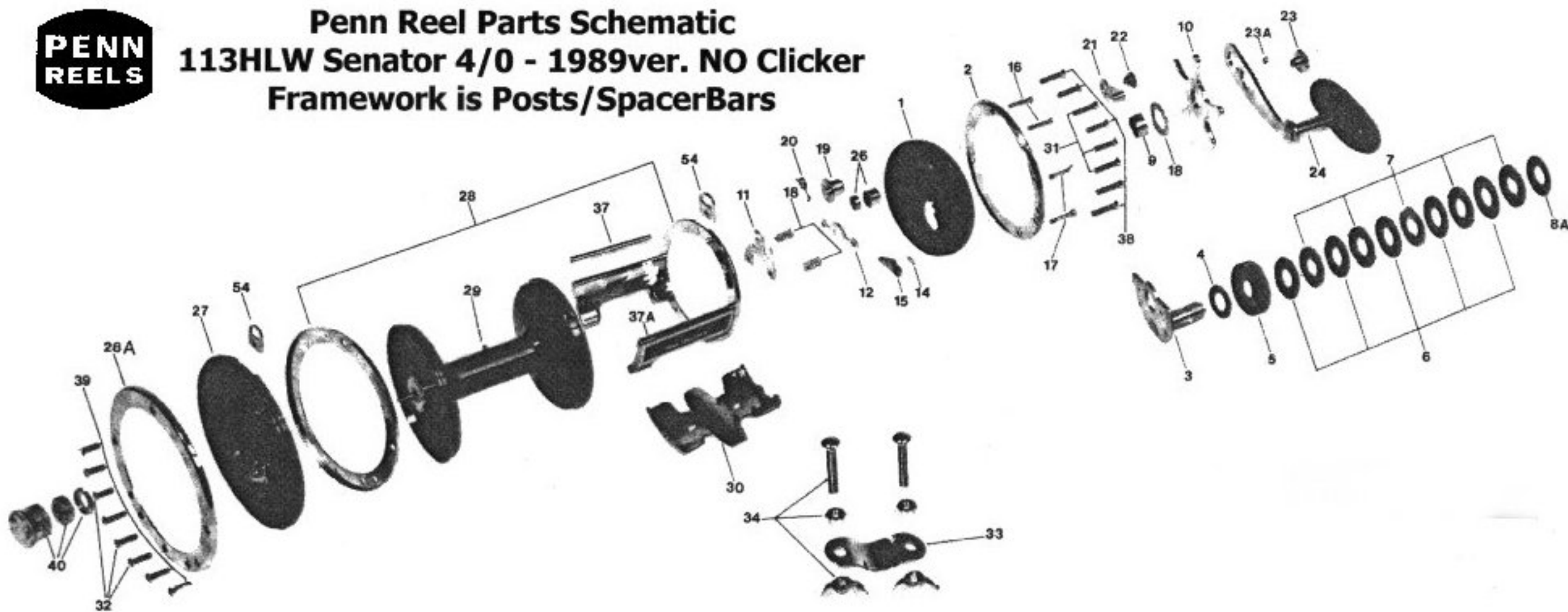

Penn Reel Parts list for:

Model: 113HLW 1989

KEY PART

NO	NO.	DESCRIPTION
1	1-113H	RIGHT SIDE PLATE
2	2-113H-O	OUTER RING SIDE RING
3	3-113H	BRIDGE W/ SLEEVE
4	4-349	FIBER WASHER
5	5-113H	MAIN GEAR
6	6-113H	DRAG WASHER (5 REQ.)
7	7-113H	METAL WASHER SET
8	8-349	TENSION SPRING
8A	18-970	TENSION SPRING DRAG
9	9-113H	SPACING SLEEVE
10	10-349	STAR DRAG WHEEL
11	11-113	ECCENTRIC JACK
12	12-60	PINION YOKE
13	13-113H	PINION
14	14-99	DOG SPRING
15	15-113H	DOG
16	16-113H	LOWER BRIDGE SCREW
17	17-113H	UPPER BRIDGE SCREW
18	18-60	CLUTCH SPRING
19	19-113	ECCENTRIC
20	20-155	ECCENTRIC SPRING
21	21-66	ECCENTRIC LEVER
22	22-99	ECCENTRIC SCREW

KEY PART

NO	NO.	DESCRIPTION
23	23-114	HANDLE SCREW
23A	110-60	HANDLE LOCK SCREW
24	24-349H	HANDLE
26	26-113H	RIGHT SIDE BEARING
27	27-113H	LEFT SIDE PLATE
28	2-113-I	INNER SIDE RING
28A	2-113-O	OUTER LEFT SIDE RING
29L	29L-113HLW	SPOOL
30	30-113HLW	STAND
31	39-3	RIGHT SIDE STAND SCREW
32	32-17	LEFT SIDE STAND SCREW
33	33-200	ROD CLAMP
*	33R-200	RINGED ROD CLAMP (N/S)
34	34-200	CLAMP SCREW W/NUTS
37	37-113HLW	FRAME POST (113HLW)
37A	37N-113HLW	SPACER BAR (FRONT "113HLW")
37C	37C-113HLW	SPACER BAR (REAR "Penn Senator II")
*	37A-113HLW	SPACER BAR (SET)
38	39-9	RIGHT SIDE POST SCREW
39	39-3	LEFT SIDE SCREW
40	40-113H	LEFT SIDE BEARING
54	54-113	HARNES LUG