

## REPAIR MANUAL SHEET MLX-200

Shimano American Corporation, 205 Jefferson Road  
Parsippany, N.J. 07054

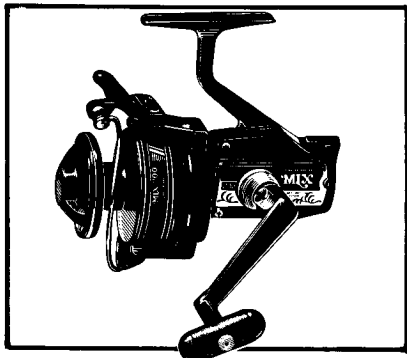

### MLX-200

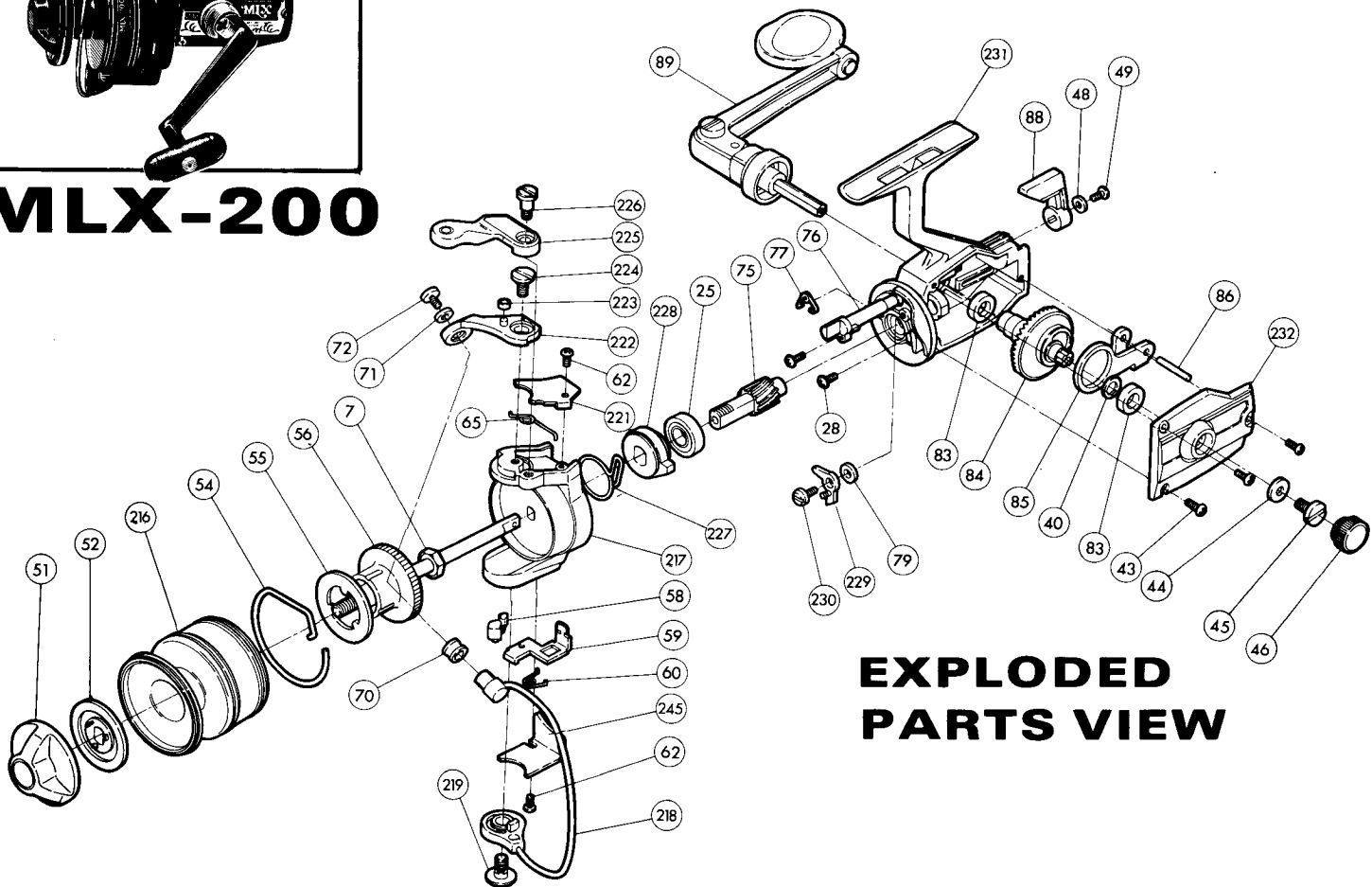

### EXPLODED PARTS VIEW

### PARTS LIST

PART#	DESCRIPTION	PRICE	PART#	DESCRIPTION	PRICE	PART#	DESCRIPTION	PRICE
7	Rotor nut	.15	60	Trip plate spring	.25	217	Rotor	4.25
25	Ball bearing	5.00	62	Cover screw	.25	218	Bail wire	2.00
28	Bearing retainer screw	.15	65	Bail spring	.25	219	Bail wire screw	.45
40	Drive gear spacer (optional)	.15	70	Roller line guide	.50	221	Bail spring cover	.45
43	Side plate screw	.15	71	Lock washer	.15	222	Bail mount	1.50
44	Lock washer	.15	72	Bail wire screw	.25	223	Trigger pin roller	.15
45	Handle screw	.15	75	Pinion gear	2.00	224	Bail mount screw	.35
46	Dust cap	.25	76	Anti reverse shaft	.60	225	Fast cast trigger	2.00
48	Anti reverse lever lock wash.	.15	77	Anti reverse shaft spring	.15	226	Trigger screw	.25
49	Anti reverse lever screw	.15	79	Anti reverse dog spacer	.15	227	Rotor stop spring	.35
51	Drag adjusting knob	1.25	83	Drive gear bushing	.45	228	Self center ratchet	1.00
52	Drag disk	.25	84	Drive gear	1.00	229	Anti reverse dog	.50
54	Click Spring	.35	85	Oscillation guide	.25	230	Anti reverse dog screw	.50
55	Base drag washer	.15	86	Oscillation guide pin	.15	231	Housing	5.50
56	Spindle	1.50	88	Anti reverse lever	.25	232	Side plate	2.75
58	Trip plate cam	.25	89	Handle	6.00	245	Trip lever cover	.35
59	Trip plate	.75	216	Spool shell	10.00			

Prices and specifications subject to change without notice.

Mar. 6 '81