

TO ORDER:
This reel belongs to the "Bantam" series.
Please order parts using the abbreviation
"BNT" and the part number.

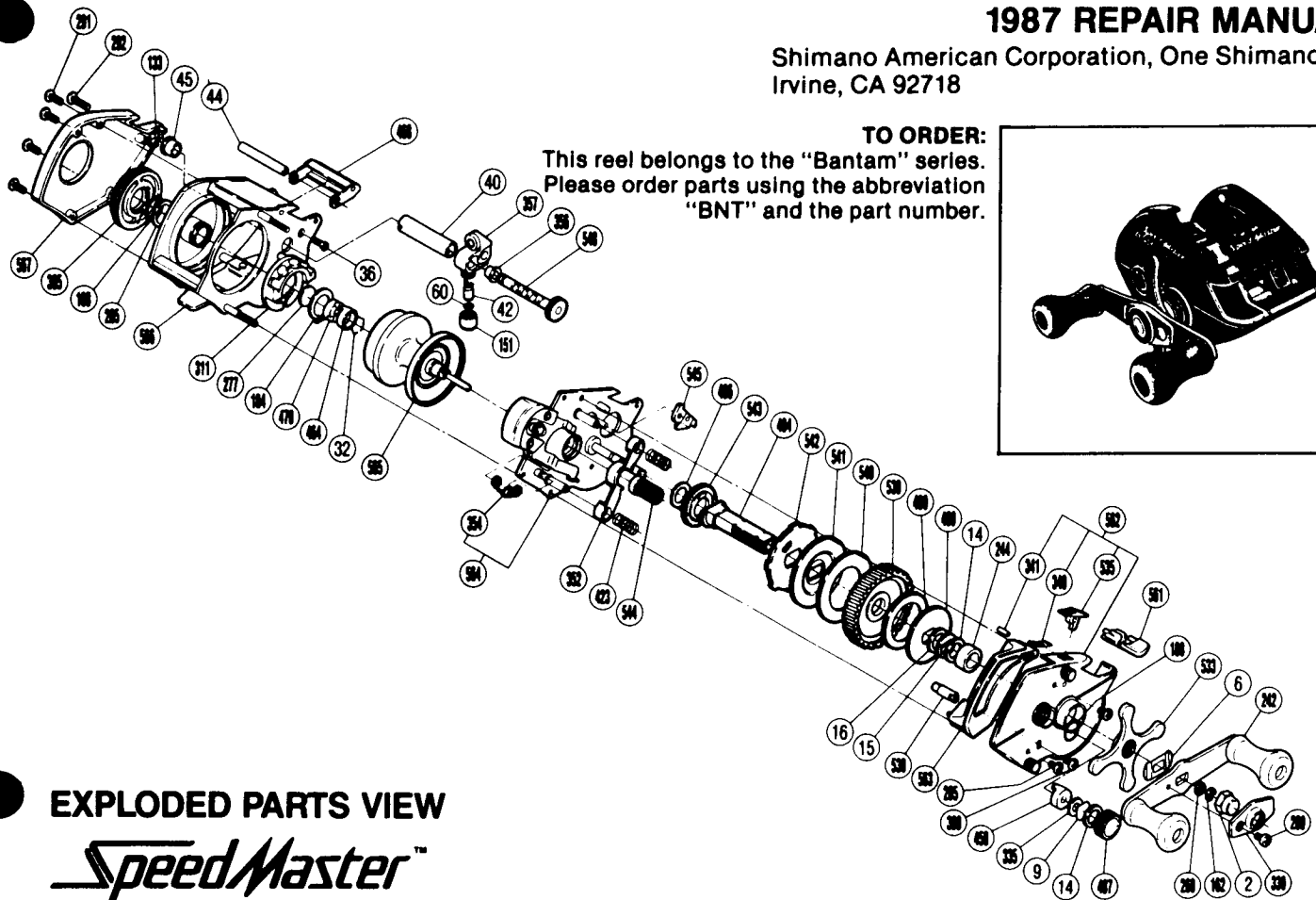
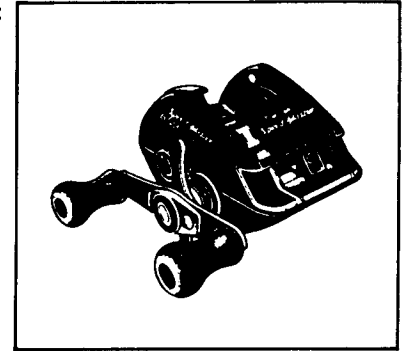

EXPLODED PARTS VIEW

Speed Master™ BSM 1550

PARTS LIST

PART # DESCRIPTION

- 2. Handle Nut
- 6. Friction Washer (A)
- 9. Spacer (A)
- 14. Friction Washer (B)
- 15. Drag Spring Washer
- 16. Friction Washer (C)
- 32. Bearing Retainer
- 36. Stabilizer Bar Screw (A)
- 40. Level Wind Guard
- 42. Line Guide Pawl
- 44. Line Guide Stabilizer Bar
- 45. Worm Bearing (B)
- 60. Spacer (Optional)
- 133. Worm Shaft Retainer
- 151. Pawl Cap
- 162. Drive Shaft Retainer
- 184. Magnet Retainer Lock
- 188. O Ring
- 242. Handle
- 244. Bushing (B)
- 265. Spacer (Optional)
- 268. Drive Shaft Washer (A)
- 277. Spacer (B)

PART # DESCRIPTION

- 280. Handle Screw "B"
- 285. Set Plate Screw
- 291. Side Plate Screw
- 292. Stabilizer Bar Screw (B)
- 311. Magnet Retainer
- 330. Handle Nut Lock Plate
- 335. Bearing Washer (A)
- 340. Switch Spring
- 341. Switch Spring Lock
- 352. Pinion Yoke
- 354. Retractor Spring
- 356. Worm Bearing "A"
- 357. Line Guide
- 365. Magnetic Control Dial
- 399. Retractor Guide Screw
(Large Head)
- 423. Yoke Spring
- 458. Bushing "A"
- 464. Bearing Spacer
- 468. Level Wind Protector
- 470. Bushing "C"
- 487. Cast Control Cap

PART # DESCRIPTION

- 489. Key Washer "A"
- 490. Drag Washer
- 494. Drive Shaft
- 496. Drive Shaft Washer "C"
- 533. Star Drag
- 535. Anti-Reverse Switch
- 538. Retractor Guide
- 539. Drive Gear
- 540. Drive Shaft Washer "B"
- 541. Key Washer "B"
- 542. Anti-Reverse Ratchet
- 543. Idle Gear
- 544. Pinion Gear
- 545. Anti-Reverse Pawl
- 548. Worm Shaft
- 561. Right Side Plate Cover
- 562. Right Side Plate
- 563. Clutch Button Attachment
- 564. Set Plate Assembly
- 565. Spool
- 566. Frame
- 567. Left Side Plate