

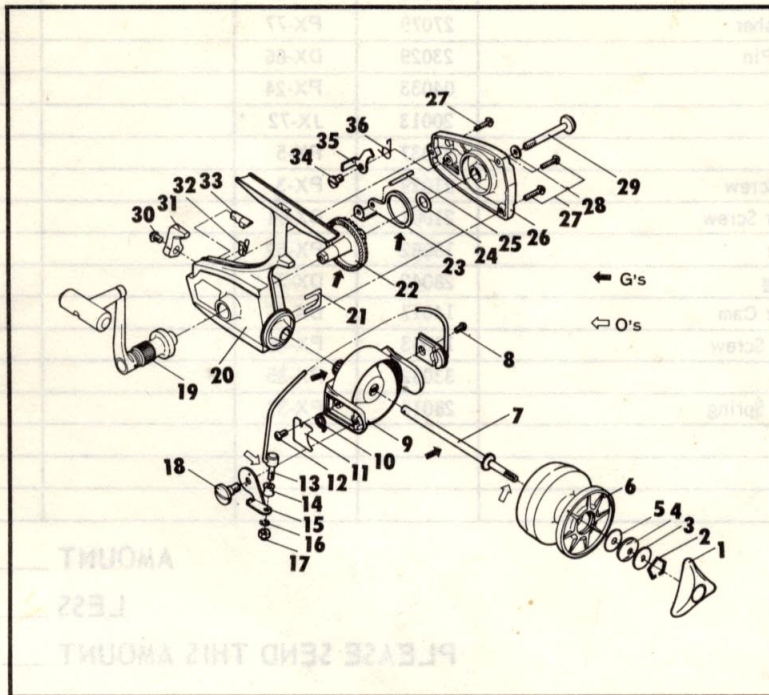

BRUNSWICK CORPORATION
 CONSUMER DIVISION
 POST OFFICE BOX 270
 TULSA, OKLAHOMA 74101

ZEBCO PARTS LIST AND ORDER BLANK MODEL SRL30 SPINNING REEL

PLEASE ORDER BY PART NUMBER, NOT KEY NUMBER.



IF REQUIRED REPAIRS CANNOT BE MADE AT YOUR NEAREST FACTORY APPROVED SERVICE STATION, YOU MAY ORDER THE FOLLOWING REPLACEMENT PARTS DIRECT FROM THE FACTORY OR RETURN REEL TO FACTORY.

Your Order No. _____ Date _____
 Charge To _____ Ship To _____
 Address _____ Address _____
 City & State _____ City & State _____

DEFECTIVE PARTS REPLACED AT FACTORY ONLY

KEY NO. .	DESCRIPTION	PART NUMBER		QUANTITY	PRICE	EXTENSION
		old	new			
1	Drag Knob Assembly	0232019	PX-32		\$.75	
2	Stopper Spring	29023	PX-28		.10	
3	Drag Washer A	27046	PX-53		.10	
4	Spring Washer	27082	PX-30		.20	
5	Drag Washer B	27075	PX-54		.05	
6	Spool Assembly	0206031A	PX-21		1.15	
7	Main Shaft Assembly	0212084	PX-15		1.35	
8	Balanced Weight Screw	21003	BX-47		.10	
9	Rotor Assembly	0205022	PX-9-A		5.00	
10	Bail Arm Spring	28106	PX-49		.20	
11	Bail Arm Spring Cover	41009	PX-13		.20	
12	Bail Arm Spring Cover Screw	20023	PX-14		.05	
13	Bail Arm Assembly	0229034	PX-10-A		2.55	
14	Bail Arm Roller	25009	DX-4		.35	
15	Bail Arm Lever	15064	PX-43		.70	
16	Spring Washer	27021	CX-17		.10	
17	Bail Arm Nut	18005	BX-19		.15	
18	Bail Arm Cam Screw	21031	PX-16		.90	